

Ultra-low frequency electromagnetic monitoring within PBO

Simon Klemperer, Tony Fraser-Smith, Greg Beroza, Darcy Karakelian

Department of Geophysics, Stanford University, CA 94305-2215 sklemp@stanford.edu

Summary

The executive Summary to the PBO White Paper reminds us that “The problems that we seek to address require more than geodetic data.” In response we propose a network of 12 ultra-low frequency electromagnetic (ULF EM) recording sites in California as a necessary part of the PBO mission to understand earthquake physics and to detect pre-seismic transients if such exist.

Ultra-low frequency (0.01-10 Hz) magnetic field anomalies prior to and following $M > 6.5$ earthquakes have been reported from a number of different regions of the world. If real, these signals contain important information about the physics of earthquakes, particularly fluid motion in and around the fault before during and after seismic activity. Collocation of magnetic sensors with PBO strain-meters and seismometers would allow signals from hypocentral regions to be separated from artifacts related to sensor tilt. Identical, spatially separated recorders are necessary to exclude other potential sources of magnetic signals. Continuous recording of the magnetic and electric field before, during and after, and spatially close to, a significant earthquake, is required to demonstrate the reality or absence of ULF EM signals. The location of a number of ULF EM recording sites along the San Andreas and other major faults within the framework of PBO offers a unique opportunity to study ULF EM signals, and to expand our knowledge of the physics of earthquakes.

Rationale – why EM?

The underlying motivation for PBO includes the wish to understand the physics of earthquakes and the detailed geological structure of the faults on which they occur. Specific questions PBO seeks to answer include: “Can we observe a nucleation phase? Are there preseismic transients that could form the basis for predictive capability? While there have been tantalizing preseismic signals to earthquakes over the years, few have been sufficiently well-documented to be definitively confirmed or rejected. This is largely due to the absence of instrumentation in the zone of the impending earthquake.” [quote from PBO White Paper, www.earthscope.org/PBOwhitepaper.pdf]. Studies of active and ancient faults show that crustal fluids are ubiquitous [1, 2] and play a key role in the detailed physics of earthquakes [3]. The best geophysical method to detect the presence and participation of fluids in the earthquake cycle is electromagnetic monitoring which unlike all other geophysical methods is sensitive to the presence of only a few percent of water.

Rationale - why ULF?

Reported claims of EM anomalies associated with earthquakes extend over a large frequency range, from megahertz down to quasi-dc. We focus on the ULF part of the EM spectrum (0.01-10 Hz) because these are the highest frequency signals that can reach the Earth’s surface with little attenuation if they are generated at typical California earthquake nucleation depths (~10 km). ULF magnetic anomalies prior to $M > 6.5$ earthquakes have been reported prior to the 12/7/88 $M_s=6.9$ Spitak, Armenia earthquake [4], and prior to the 8/8/93 $M_s = 8.0$ Guam earthquake [5], but perhaps most notably prior to the Loma Prieta $M_s = 7.1$ earthquake [6] (Figure 1). Published physical explanations of the Loma Prieta anomaly all rely on the presence of fluids in the fault zone [7, 8, 9]. Study of these EM fields offers the potential of understanding the volume and distribution of these fluids, and the role they play in seismic activity.

There are fewer reports of ULF anomalies associated with smaller magnitude earthquakes ($M < 6$) and aftershocks of major earthquakes [10, 11]. The nucleation phase of an earthquake scales with its total seismic moment [12]. Our calculations, based on physical models of EM sources and scaled to the Loma Prieta EM signals, suggest that earthquakes along the San Andreas fault of $M \leq 5$ cannot produce detectable surface signals, given the background noise levels typically recorded by geomagnetic sensors [13].

Rationale - why include ULF EM within PBO?

Most suggested precursory earthquake anomalies were recorded serendipitously by observing systems established for other purposes. They lack the simultaneous corroborative observations on identical but spatially separated measurement systems, and/or the long-term recorded time series on each individual system, that are necessary to exclude other potential sources of EM activity and thereby to establish the credibility of the claims. Permanent EM observatories may require researchers to wait for decades for the occurrence of even one sufficiently large, sufficiently close, earthquake to test whether that earthquake had associated EM signals (preseismic, coseismic, or postseismic). Current “permanent” ULF-EM stations developed in California in the aftermath of the

Loma Prieta earthquake are operating with zero long-term funding base, so cannot be routinely maintained. Verification of the existence of EM earthquake anomalies requires maintenance of an observatory during an entire earthquake cycle, and so requires the supporting infrastructure of a project such as PBO that will exist over the appropriate time-scale.

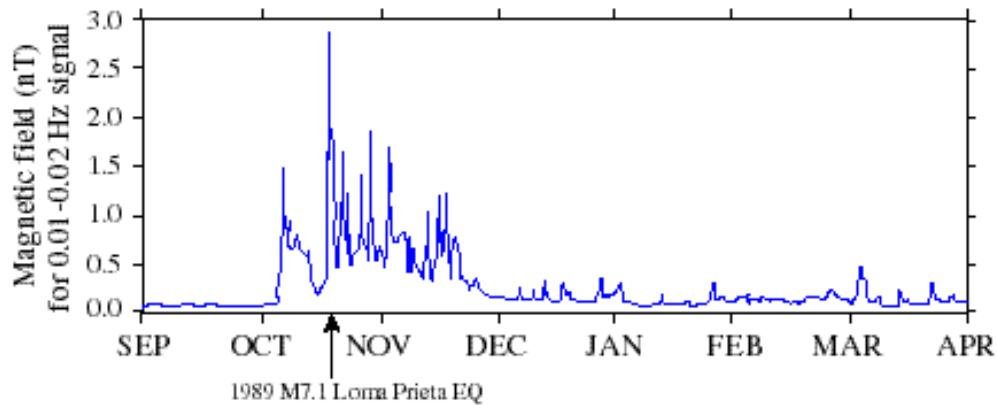

Figure 1
Magnetic field activity at Cormilito, CA (COR on Figure 3) from 9/89 – 4/90. Note increase in activity two weeks prior to the main shock, much larger amplitudes starting three hours before the main shock (Fraser-Smith et al., 1993) and the continuing high fields for over a month following the main shock (Fenoglio et al., 1993).

Equipment and Costs

Our model site has three orthogonal magnetometers, and two orthogonal (horizontal) electric dipoles [14] (Figure 2). Though the magnetometers are small, electrode separation should be 50 to 100 m. At sites where physical restrictions or land-ownership issues prevent deployment of electric dipoles, use of three magnetometers alone is an adequate (though sub-ideal) solution. Three magnetometers and power supplies cost c. \$22k in total; four electrodes, cabling and electric-field signal conditioner cost c. \$8k; miscellaneous installation costs less than \$5k per

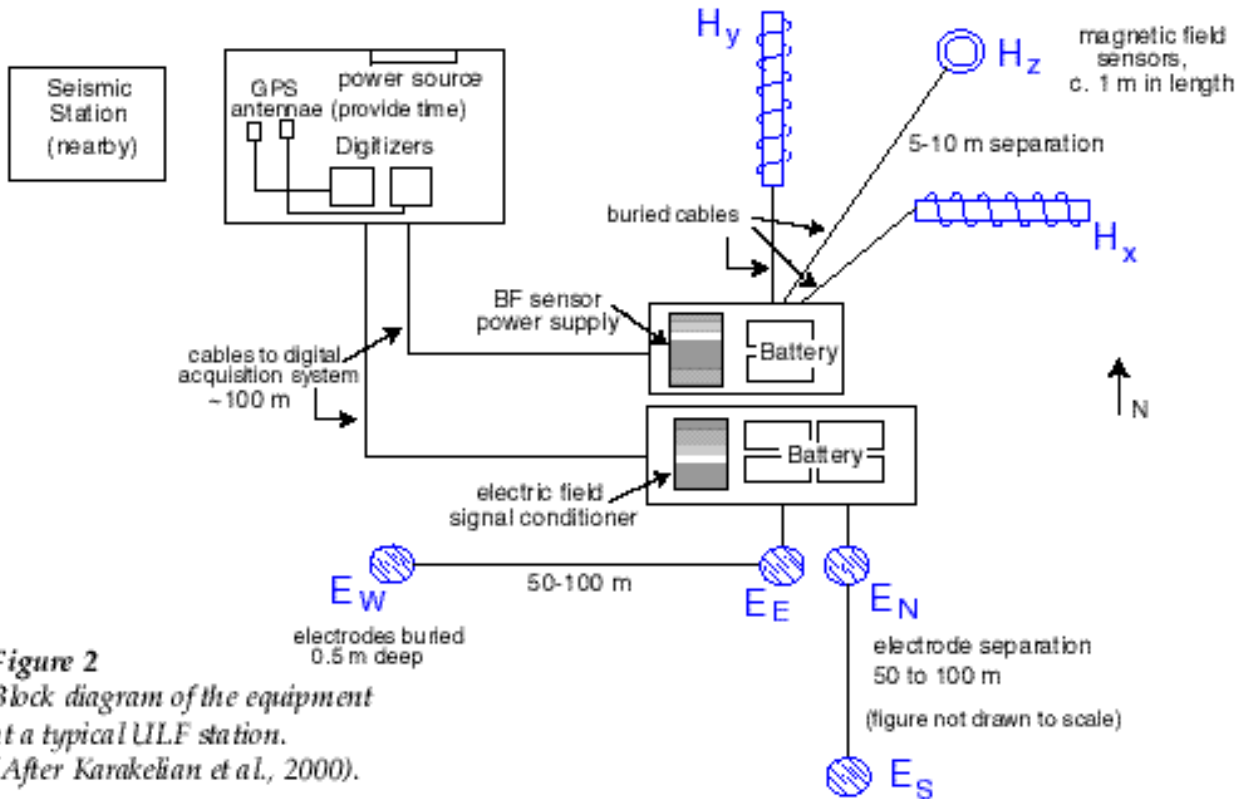

Figure 2
Block diagram of the equipment at a typical ULF station. (After Karakehian et al., 2000).

site (ditch digging and hole auguring, etc.). We typically sample at 40 Hz, and costs of digitizers (e.g. Quanterra data-loggers) and telemetry should be the same as for any other instrument package at a PBO observatory. Thus the hardware-and-installation cost of the 12-station array described below is *c.* \$400k, to which should be added costs of digitization, telemetry, data archiving and data analysis. Background activity at a quiet station away from anthropogenic noise (major power lines or electric railways) may be of the order of 20 pT at 0.01 Hz. An example recording is the co-seismic signal from a $M_w = 5.1$ earthquake recorded on a five-component (magnetic and electric) station and collocated broadband seismic station (Figure 3). The visible co-seismic EM signal records the motion of the sensors in the earth's magnetic field (the same motion as the adjacent seismometer) and also an electro-seismic component due to charge-separation induced by passage of the seismic waves through saturated or partially saturated near-surface strata adjacent to the sensors [15].

If the two existing UC Berkeley EM sites at SAO and PKD can continue to be maintained, conceivably as part of a PBO network, then we would request only 10 new stations. Additional possible cost-savings (possible cost-sharing) of up to \$80k could arise through the incorporation of existing Stanford-owned magnetometers into PBO observatory sites: there is the potential that two to four sets of three-component magnetometers could be relocated from their current (unfunded, sporadically maintained) Stanford sites to PBO observatories.

Siting strategy

Meaningful analysis of ULF EM signals can only be done using continuous recordings at multiple sites, in order to remove natural variations in the external (solar) field. Records from a single station (as with the ULF EM signals recorded prior to the Loma Prieta earthquake) are not sufficient to overcome the burden of proof required of proposed earthquake precursors, so stations should be close enough that two stations can record EM signals from a single earthquake. Calculation of the expected attenuation of ULF EM signals during passage through the earth and along the surface of the earth, suggests that Loma Prieta-type signals (*c.* 5 nT at the hypocenter) can be detected above noise level to a distance of about 100 km, for a ULF-EM station in a quiet environment (i.e. away from a major urban area) [6]. [The $M = 6.7$ Northridge earthquake, from which no EM signals were detected, was 80 km from the closest station (which was then operating with higher than usual noise levels due to a magnetic storm) [16]]. We therefore propose siting ULF-EM stations at *c.* 100 km intervals along the San Andreas Fault in California, and in the seismically active Mojave Desert region. A total of 12 such stations would provide reasonable assurance that Loma-Prieta type signals associated with any future $M > 7$ San Andreas earthquake would be detectable by at least one, and probably two, PBO stations.

Although a denser network of ULF EM stations would be highly desirable to ensure signal detection and to allow study of signal decay with epicentral distance, densification may be inappropriate until more is known about the origin of the signals. A 100-km-spaced ULF EM network can be supplemented by transportable recording systems deployed in a rapid response mode in the aftershock region of a major earthquake to record post-seismic EM activity due to the main shock, as well as any precursory and/or coseismic EM signals associated with aftershocks [14]. Stanford already owns two rapid-response systems which can be used to supplement the proposed, relatively sparse, 12-station permanent network.

Figure 4 shows existing permanent ULF EM sites in California, and Figure 5 is a conceptual deployment for a PBO ULF EM network, collocated with 12 existing digital seismograph stations as examples of appropriate locations for ULF EM sensors. We expect the PBO ULF EM array would supersede existing Stanford sites (Figure 4), where possible making use of our existing equipment. We anticipate moving existing stations away from the central Bay Area [MPK and LKC are ideal sites for monitoring the Hayward fault, but their records are dominated by BART (electric train) noise]. We envision existing UCB sites SAO and PKD (Figure 4) as important elements in a PBO array. We have invited Dr. H.F. Morrison (of UC Berkeley who operates stations at SAO and PKD) and Dr. S. Park (of UC Riverside, who has long experience of electric-field measurements) to participate equally in this proposal.

Summary

We present a low-cost approach for PBO to incorporate meaningful electromagnetic monitoring into its program to understand the physical basis for earthquakes, thereby potentially enabling major discoveries about earthquake-related fluid flow.

References

1. Unsworth, M.J., Malin, P.E., Egbert, G.E., and Booker, J.R. 1997. *Geology*, **25**, 359-362.
2. Evans, J.P., and Chester, F.M. 1995. *JGR*, **100**, 13,007-13,020.
3. Hickman, S., Sibson, R., and Bruhn, R. 1995. *JGR*, **100**, 12,831-12,840.
4. Kopytenko, Yu.A., T.G. Matiashvili, P.M. Voronov, E.A. Kopytenko, and O.A. Molchanov 1993. *Phys. Earth Planet. Int.* **77**, 85-95.

5. Hayakawa, M., R. Kawate, O. A. Molchanov, and K. Yumoto. 1996. *GRL*, **23**, 241-244.
6. Fraser-Smith, A.C., Bernardi, A., Helliwell, R.A., McGill, P.R., and Villard, O.G. Jr. 1993. *USGS Prof. Paper 1550-C*, C17-C251.
7. Draganov, A.B., U.S. Inan, and Y.N. Taranenko. 1991. *GRL*, **18**, 1127-1130.
8. Fenoglio, M.A., M. J. S. Johnston, and J. D. Byerlee. 1995. *JGR*, **100**, 12,951-12,958.
9. Merzer, M. and S.L. Klemperer. 1997. *PAGEOPH*, **150**, 217-248.
10. Fenoglio, M.A., A. Fraser-Smith, G. Beroza, and M.J.S. Johnston. 1993. *BSSA*, **83**, 347-357.
11. Park, S., M Johnston, T Madden, F Morgan, and H Morrison. 1993. *Rev. Geophys.*, **31**, 117-132.
12. Beroza, G.C., and Ellsworth, W.L. 1996. *Tectonophysics*, **261**, 209-227.
13. Karakelian, D., Klemperer, S.L., Thompson, G.A., and Fraser-Smith, A.C. 2000. *Proc. 3rd conf. "Tectonic problems of the San Andreas Fault System"*, Stanford, CA, eds. G. Bokelmann and R.L. Kovach, 334-346.
14. Karakelian, D., Klemperer, S.L., Fraser-Smith, A.C., and Beroza, G.C. 2000. *Seismological Research Letters*, **71**, 423-436.
15. Haartsen, M., and Pride, S.R. 1997. *JGR*, **102**, 24,745-24,769.
16. Fraser-Smith, A.C., McGill, P., Helliwell, R., and Villard, O., Jr. 1994. *GRL*, **21**, 2195-2198.

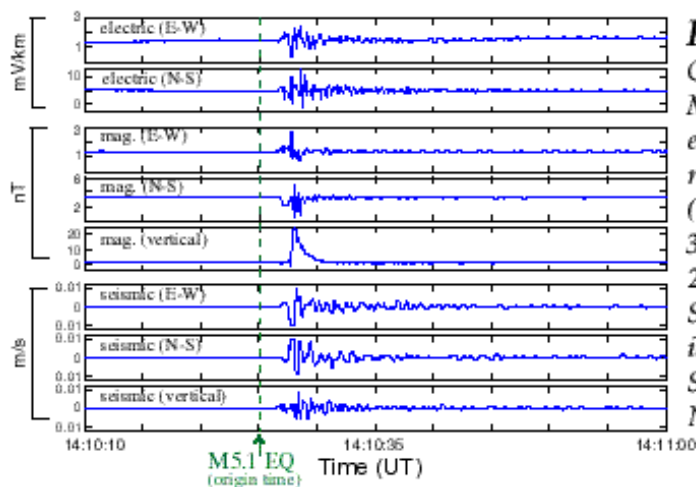

Figure 3
Co-seismic record for the 8/12/98 $M_w=5.1$ San Juan Bautista earthquake, recorded at BDSN seismograph SAO (see Figure 4), and its collocated 3-component magnetometer and 2-component electric field recorders. Sampled at 10 Hz and corrected for instrument response. Seismic and EM data courtesy of NCEDC & Dr. H.F. Morrison, UCB.

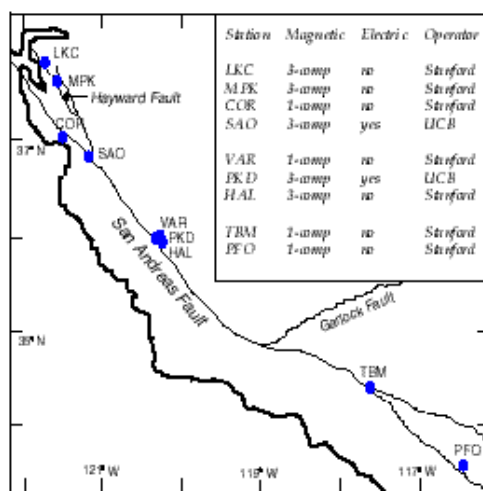

Figure 4.
Location of permanent ULF EM stations in California in October 2000. After Karakelian et al., 2000.

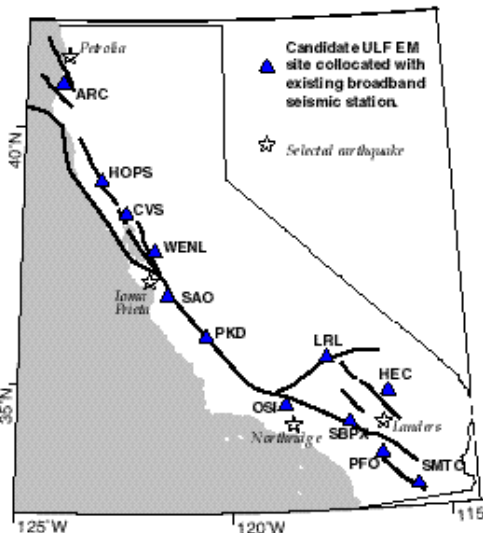

Figure 5.
Possible siting scheme for ULF EM stations spaced at c. 100 km along the San Andreas, outside urban areas. As a straw-man we show 12 existing broadband stations, and utilize existing ULF EM sites at SAO, PKD and PFO.